

LIQUID CRYSTAL DISPLAY MODULE

Product Specification

DENSITRON	STANDARD LCD MODULE	
PRODUCT NUMBER	LWM12864B-SERIES	
DEFINITION	Display 128*64 dots	Date 28/01/08

INTERNAL APPROVALS				
Quality Mgr	Product Mgr	Project Leader	Mech. Eng	Electr. Eng
Date:	Date:	Date:	Date:	Date:

TABLE OF CONTENTS

PRODUCT SPECIFICATION	1
TABLE OF CONTENTS	2
1 PART NUMBERING SYSTEM	4
2 MAIN FEATURES	6
3 MECHANICAL SPECIFICATION	7
3.1 MECHANICAL CHARACTERISTICS.....	7
3.2 MECHANICAL DRAWING.....	8
4 ELECTRICAL SPECIFICATION	8
4.1 ABSOLUTE MAXIMUM RATINGS	9
4.2 ELECTRICAL CHARACTERISTICS.....	9
4.3 INTERFACE PIN ASSIGNMENT	10
4.4 INTERFACE BLOCK DIAGRAM.....	11
4.5 DISPLAY CONTROL INSTRUCTION.....	12
5 OPTICAL SPECIFICATION	15
6 TOUCH SCREEN SPECIFICATION_IN DEVELOPMENT	16
7 BACKLIGHT SPECIFICATION	16
7.1 LED BACKLIGHT CHARACTERISTICS.....	17
7.1.1 <i>WHITE EDGE STANDARD LED BACKLIGHT CHARACTERISTICS</i>	17
7.1.2 <i>YELLOW GREEN STANDARD LED BACKLIGHT CHARACTERISTICS</i>	17
7.1.3 <i>BLUE STANDARD LED BACKLIGHT CHARACTERISTICS</i>	17
7.1.4 <i>TRI-COLOUR LED BACKLIGHT CHARACTERISTICS</i>	17
7.2 EL BACKLIGHT CHARACTERISTICS.....	19
8 QUALITY ASSURANCE SPECIFICATION	19
8.1 CONFORMITY	19
8.2 DELIVERY ASSURANCE	19
8.2.1 <i>Delivery inspection standards</i>	19
8.2.2 <i>Zone definition</i>	20
8.2.3 <i>Visual inspection</i>	20
8.2.4 <i>Standard of appearance inspection</i>	21
9 RELIABILITY SPECIFICATION	23
10 HANDLING PRECAUTIONS	24

REVISION RECORD

Rev.	Date	Page	Chapt.	Comment	ECR no.
1	28/01/2008			Initial Specification	

1 PART NUMBERING SYSTEM

LWM 12864B - BW - WCY *
 Densitron mono module ① ② ③ ④ ⑤ ⑥

① Characters x Row format

② Model serials number

③ Display mode and backlight type :

A = Reflective (without backlight) =

B* = Transflective positive LEDS array type backlight (BG, BA, BW, BR, BT ...)

B*(E) = Transflective LEDS edge type backlight (BGE, BAE, BWE, BR...)

B = Transflective CFL

C* = Transflective positive EL backlight (CB, CW)

D* = Transmissive negative EL backlight (DB, DW)

E = CFL

E* = Transmissive negative LEDS array type backlight (EG, EA, EW, ER...)

E*(E) = Transmissive negative LEDS edge type backlight (EGE, EAE, EWE, ERE...)

(* color LED or EL backlight = G/ yellow-green, A/ amber, W/ white, R/ red, B/blue ,T/ tricolour)

④ Temperature range and power supply

D = Standard temperature range; negative supply voltage required (0°C~+50°C)

S = Standard temperature range; on board negative voltage generator (0°C~+50°C)

H= Wide temperature range; negative supply voltage required (-20°C ~+70°C)

W= Wide temperature range; on board negative voltage generator (-20°C ~+70°C)

⑤ Fluid type and compensation circuit option

NY = STN yellow-green glass, without temperature compensation circuit

CY = STN yellow green glass, with temperature compensation circuit on board

NG = STN gray glass without temperature compensation circuit

CG = STN gray glass with temperature compensation circuit

NB = STN blue glass, without temperature compensation circuit

CB = STN blue glass with temperature compensation circuit

NF = FSTN black and white glass without temperature compensation circuit

CF = FSTN black and white glass with temperature circuit on board

⑥ Special code for customized features

Please refer to our commercial office

Remarks and definitions :

1°) Display mode and backlight type :

- Reflective polarizer, no backlight, usable only in good ambient light conditions.
- Transflective polarizer uses a background backlight and a mirror reflector, usable in all lighting conditions.
- Transmissive polarizer needs the backlight switched on continuously, usable mostly in low ambient light conditions
- EL (electro-luminescent), uniform brightness, short life time (8000 hours max), needs EL inverter, low current consumption, low thickness.
- LED (light emitting diode), uniform brightness, long lifetime (100 000 hours), doesn't need inverter, reliable in vibration and shock environment, different colors available.

Array version is a direct lighting type, available in standard form, uniform and good brightness on all the active area.

Edge version is an edge lighting type providing a low consumption backlight, has a low thickness and brightness.

- Positive mode has dark pixels on a light background
- Negative mode has light pixels in a dark background and is normally used only with a transmissive polarizer as it needs a backlight on to be visible.

2°) Fluid type :

- STN yellow green or grey LCD has a yellow green or grey background with dark blue pixels and offers a good contrast.
- FSTN LCD is to produce very high contrast with black and white pixels using a film polarizer

2 MAIN FEATURES

ITEM	CONTENTS
Display Format	128 x 64 dots
Overall Dimensions	75.0 x 52.7 x 8.9(MAX)
Viewing Area	60.0 x 32.6
LCD type	STN / FSTN
Mode	Available in Reflective / Transflective / Transmissive
Viewing Angle	6 o'clock
Duty	1/64
Driver IC	Neotec NT7107C,NT7108C
Backlight type	None / LED
Backlight colour	Yellow Green / White / Amber / Blue/ Green/ Red and tri-colour
DC/DC converter	None or Included
Operating temperature	From 0/+50°C to -20°/+70°C
Storage temperature	From -20°/+70°C to -30°/+80°C

3 MECHANICAL SPECIFICATION

3.1 MECHANICAL CHARACTERISTICS

Item	Dimension	Unit
Number of Characters	128 x 64 dots	
Module dimension	75.0 x 52.7 x 8.9(MAX)	mm
	EL or No B/L 93 x 70.0 x 9.7(MAX)	
View area	60.0 x 32.6	mm
Active area	55.0 x 27.48	mm
Dot size	0.41 x 0.41	mm
Dot pitch	0.43 x 0.43	mm

3.2 MECHANICAL DRAWING

Version LED

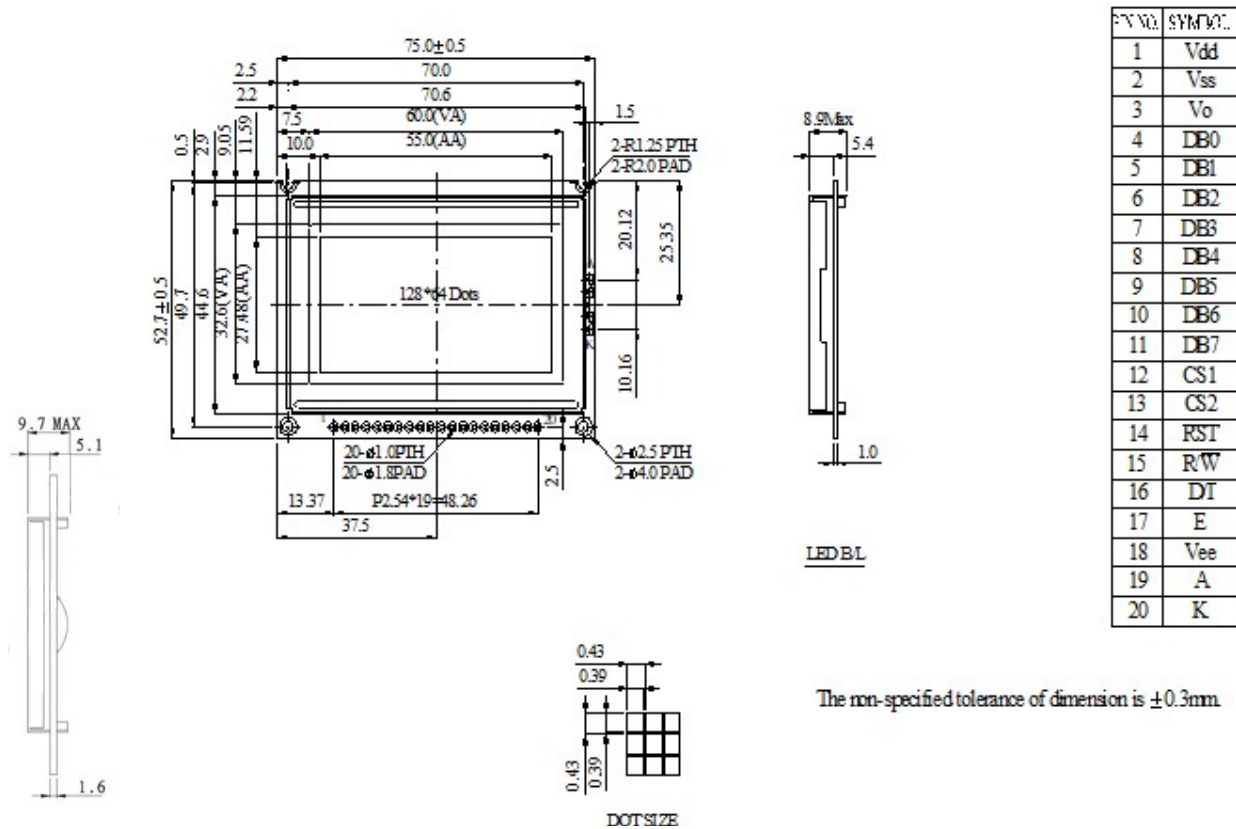

DENSITRON TECHNOLOGIES plc. reserves the right to make changes to their products without notice, and advise customers to obtain the latest version of the relevant product to verify compatibility.

4 ELECTRICAL SPECIFICATION

4.1 ABSOLUTE MAXIMUM RATINGS

ITEM	SYMBOL	MIN.	TYP.	MAX.	UNIT
Operating Temperature	T _{OP}	-20	-	+70	°C
Storage Temperature	T _{ST}	-30	-	+80	°C
Input Voltage	V _I	0		V _{DD}	V
Supply Voltage For Logic	V _{DD}	0	-	6.7	V
Supply Voltage For LCD	V _{DD} -V _{SS}	0	-	16.7	V
Supply Voltage For LCD	V _{DD} -V _{OUT}	-	-	-10	V

Note 1: Background colour changes slightly depending on ambient temperature. This phenomenon is reversible. Ta ≤ 70 °C: 75% RH max

Note 2: Ta ≤ 80 °C: 75% RH max

4.2 ELECTRICAL CHARACTERISTICS

V_{SS} = 0 V, Ta = 25 °C

Item	Symbol	Condition	Min	Typ	Max	Unit
Supply Voltage For Logic	V _{DD} -V _{SS}	—	4.5	5.0	5.5	V
Supply Voltage For LCD	V _{DD} -V ₀	Ta=-20°C	—	—	9.5	V
		Ta=25°C	—	8.5	—	V
		Ta=+70°C	7.5	—	—	V
Input High Volt.	V _{IH}	—	2.0	—	V _{DD}	V
Input Low Volt.	V _{IL}	—	0	—	0.8	V
Output High Volt.	V _{OH}	—	2.4	—	V _{DD}	V
Output Low Volt.	V _{OL}	—	0	—	0.4	V
Supply Current	I _{DD}	—	-	2.5	-	mA

* I_{DD} measurement condition is for all pattern ON

4.3 INTERFACE PIN ASSIGNMENT

Pin No.	Symbol	Level	Description
1	VDD	5.0V	Supply voltage for logic
2	V _{ss}	0V	Ground
3	V _o	(Variable)	Operating voltage for LCD
4	DB0	H/L	Data bit 0
5	DB1	H/L	Data bit 1
6	DB2	H/L	Data bit 2
7	DB3	H/L	Data bit 3
8	DB4	H/L	Data bit 4
9	DB5	H/L	Data bit 5
10	DB6	H/L	Data bit 6
11	DB7	H/L	Data bit 7
12	CS1	H	Select Column 1~ Column 64
13	CS2	H	Select Column 65~ Column 128
14	RST	L	Reset signal
15	R/W	H/L	H: Read (MPU←Module) , L: Write (MPU→Module)
16	D/I	H/L	H: Data , L : Instruction
17	E	H	Enable signal
18	V _{ee}	—	Negative Voltage output
19	A	—	Power Supply for LED backlight (+)
20	K	—	Power Supply for LED backlight (-)

4.4 Interface Block Diagram

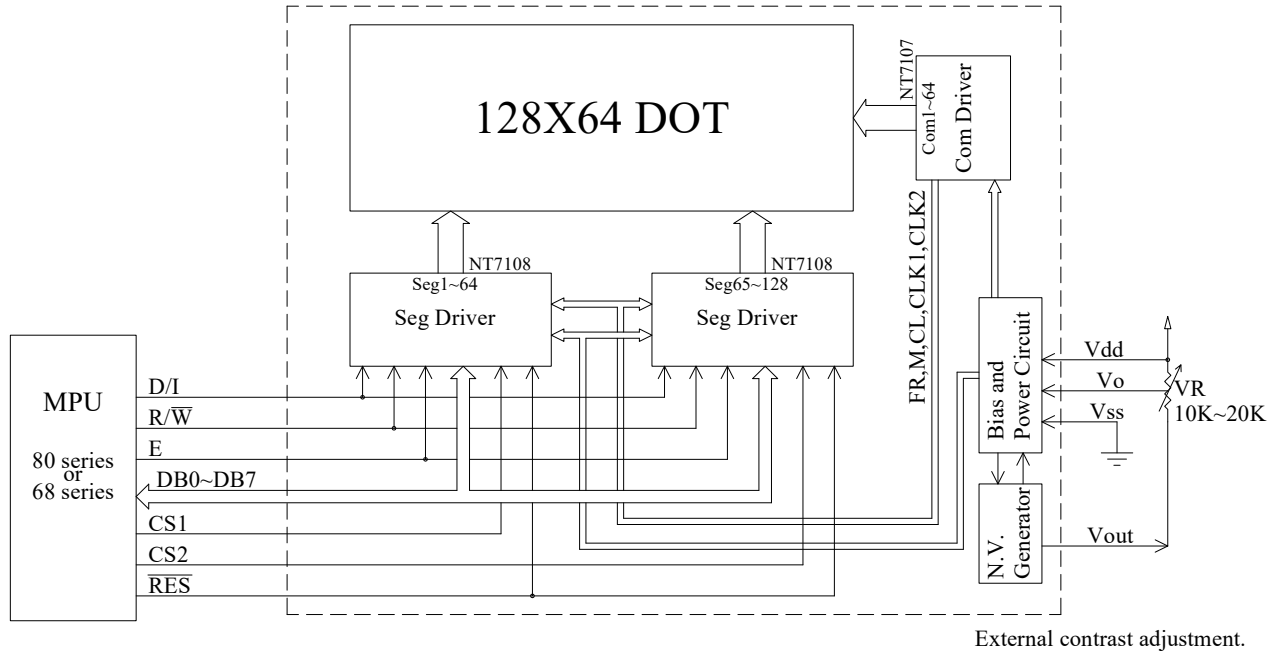

4.5 DISPLAY CONTROL INSTRUCTION

The display control instructions control the internal state of the NT7108. Instructions are received from the MPU to the NT7108 for the display control.

The following table shows various instructions.

Instruction	RS	R/W	DB7	DB6	DB5	DB4	DB3	DB2	DB1	DB0	Function	
Display on/off	L	L	L	L	H	H	H	H	H	L/H	Controls the display on or off. Internal status and display RAM data is not affected. L:OFF, H:ON	
Set address (Y address)	L	L	L	H	Y address (0-63)						Sets the Y address in the Y address counter.	
Set page (X address)	L	L	H	L	H	H	H	Page (0-7)			Sets the X address at the X address register.	
Display Start line (Z address)	L	L	H	H	Display start line (0-63)						Indicates the display data RAM displayed at the top of the screen.	
Status read	L	H	Busy	L	On/Off	Reset	L	L	L	L	Read status. BUSY L: Ready H: In operation ON/OFF L: Display ON H: Display OFF RESET L: Normal H: Reset	
Write display data	H	L	Write data									Writes data (DB0: 7) into display data RAM. After writing instruction, Y address is increased by 1 automatically.
Read display data	H	H	Read data									Reads data (DB0: 7) from display data RAM to the data bus.

RS	R/W	DB7	DB6	DB5	DB4	DB3	DB2	DB1	DB0
0	0	0	0	1	1	1	1	1	D

The display data appears when D is 1 and disappears when D is 0. Though the data is not on the screen with D=0, it remains in the display data RAM. Therefore, you can make it appear by changing D=0 into D=1.

SET ADDRESS (Y ADDRESS)

RS	R/W	DB7	DB6	DB5	DB4	DB3	DB2	DB1	DB0
0	0	0	1	AC5	AC4	AC3	AC2	AC1	AC0

Y address (AC0-AC5) of the display data RAM is set in the Y address counter. An address is set by instruction and increased by 1 automatically by read or write operations of display data.

SET PAGE (X ADDRESS)

RS	R/W	DB7	DB6	DB5	DB4	DB3	DB2	DB1	DB0
0	0	1	0	1	1	1	AC2	AC1	AC0

X address (AC0-AC2) of the display data RAM is set in the X address register. Writing or reading to or from MPU is executed in this specified page until the next page is set.

DISPLAY START LINE (Z ADDRESS)

RS	R/W	DB7	DB6	DB5	DB4	DB3	DB2	DB1	DB0
0	0	1	1	AC5	AC4	AC3	AC2	AC1	AC0

Z address (AC0-AC5) of the display data RAM is set in the display start line register and displayed at the top of the screen. When the display duty cycle is 1/64 or others (1/32-1/64), the data of total line number of LCD screen, from the line specified by display start line instruction, is displayed.

STATUS READ

RS	R/W	DB7	DB6	DB5	DB4	DB3	DB2	DB1	DB0
0	1	BUSY	0	ON/OFF	RESET	0	0	0	0

BUSY

When BUSY is 1, the Chip is executing internal operation and no instructions are accepted.
When BUSY is 0, the Chip is ready to accept any instructions.

ON/OFF

When ON/OFF is 1, the display is OFF.
When ON/OFF is 0, the display is ON.

RESET

When RESET is 1, the system is being initialized.
In this condition, no instructions except status read can be accepted.
When RESET is 0, initializing has finished and the system is in usual operation condition.

WRITE DISPLAY DATA

RS	R/W	DB7	DB6	DB5	DB4	DB3	DB2	DB1	DB0
1	0	D7	D6	D5	D4	D3	D2	D1	D0

Writes data (D0-D7) into the display data RAM. After writing instruction, Y address is increased by one automatically.

READ DISPLAY DATA

RS	R/W	DB7	DB6	DB5	DB4	DB3	DB2	DB1	DB0
1	1	D7	D6	D5	D4	D3	D2	D1	D0

Reads data (D0-D7) from the display data RAM. After reading instruction, Y address is increased by one automatically.

Timing Characteristics

MPU Interface

(T=25°C, VDD=+5.0V±0.5)

Characteristic	Symbol	Min	Typ	Max	Unit
E cycle	t _{cy}	1000	—	—	ns
E high level width	t _{whE}	450	—	—	ns
E low level width	t _{wlE}	450	—	—	ns
E rise time	t _r	—	—	25	ns
E fall time	t _f	—	—	25	ns
Address set-up time	t _{as}	140	—	—	ns
Address hold time	t _{ah}	10	—	—	ns
Data set-up time	t _{dsw}	200	—	—	ns
Data delay time	t _{ddr}	—	—	320	ns
Data hold time (write)	t _{dhw}	10	—	—	ns
Data hold time (read)	t _{dhr}	20	—	—	ns

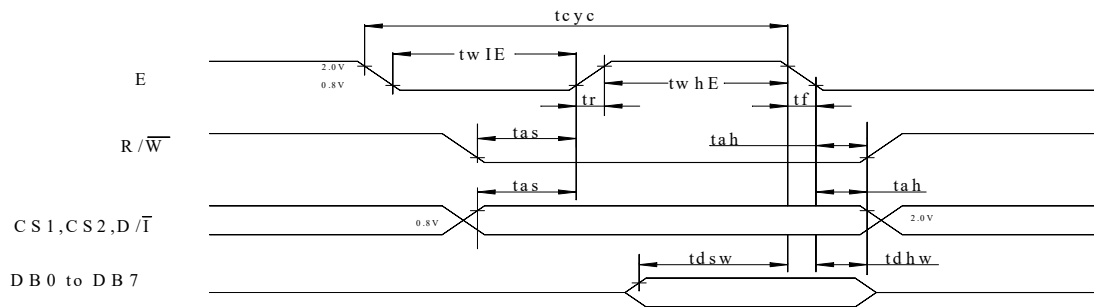

MPU Write Timing

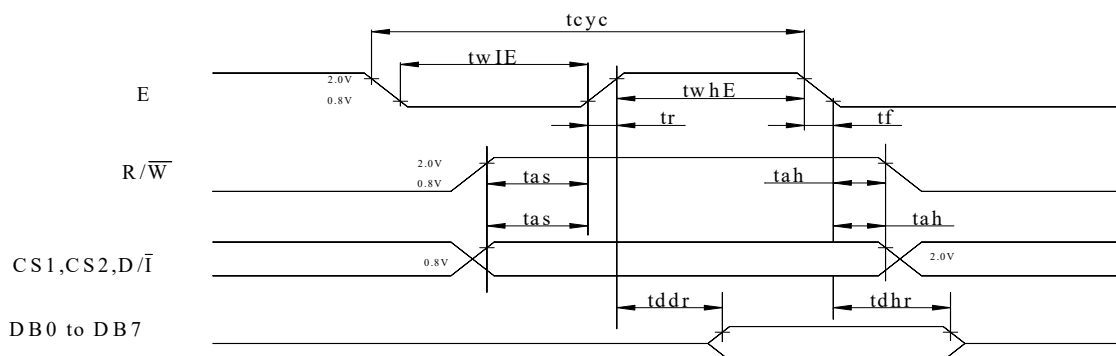

MPU Read Timing

5 OPTICAL SPECIFICATION

Item	Symbol	Condition	Min	Typ	Max	Unit
View Angle	(V) θ	$CR \geq 2$	10	—	105	deg
	(H) φ	$CR \geq 2$	-30	—	30	deg
Contrast Ratio	CR	—	—	3	—	—
Response Time	T rise	—	—	200	300	ms
	T fall	—	—	200	300	ms

Definitions ■ View Angles

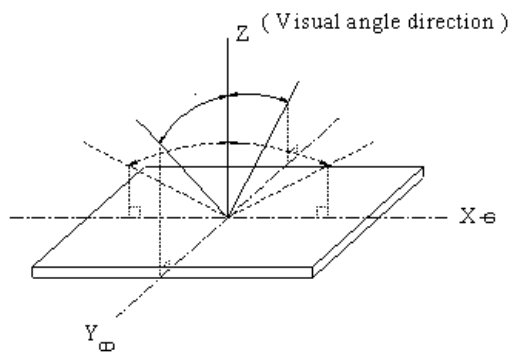

■ Contrast Ratio

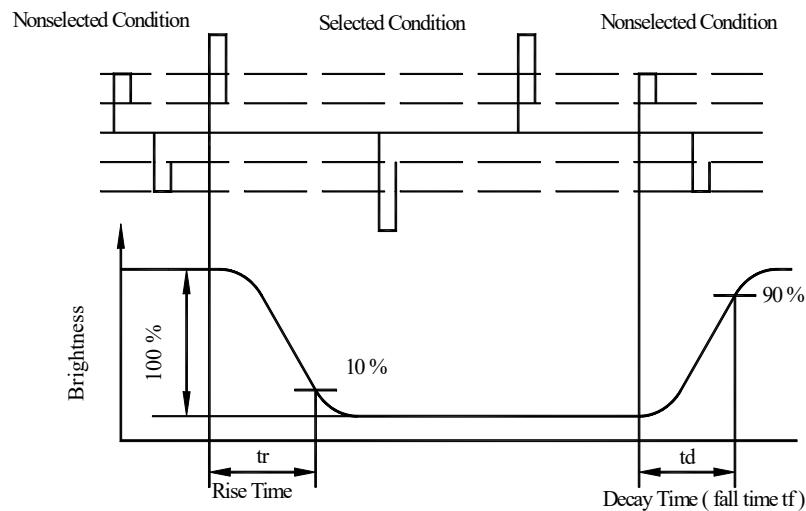
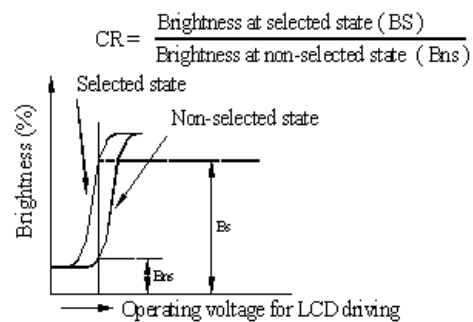

Definition of Operation Voltage (Vop)

Definition of Response Time (Tr, Tf).

6 TOUCH SCREEN SPECIFICATION

No touch option for this module

7 BACKLIGHT SPECIFICATION

7.1 LED BACKLIGHT CHARACTERISTICS

7.1.1 WHITE STANDARD LED BACKLIGHT CHARACTERISTICS

PARAMETER	SYMBOL	MIN	TYP	MAX	UNIT	TEST CONDITION
Supply Current	I _{LED}	—	60	90	mA	V=3.5V
Supply Voltage	V	—	3.5	3.7	V	—
Reverse Voltage	V _R	—	5	—	V	—
Luminous Intensity	I _V	60	—	—	cd/m ²	I _{LED} =60mA
Life Time	—	—	50K	—	Hr.	I _{LED} =60mA

7.1.2 YELLOW GREEN STANDARD LED BACKLIGHT CHARACTERISTICS

PARAMETER	SYMBOL	MIN	TYP	MAX	UNIT	TEST CONDITION
Supply Current	I _{LED}	—	100	200	mA	V=4.2V
Supply Voltage	V	—	4	4.6	V	—
Reverse Voltage	V _R	—	8	—	V	—
Luminous Intensity	I _V	60	—	—	CD/M ²	I _{LED} =100mA
Wave Length	λ p	—	570	—	nm	I _{LED} =100mA
Life Time	—	—	100K	—	Hr.	V ≤ 4.6V

7.1.3 AMBER STANDARD LED BACKLIGHT CHARACTERISTICS

PARAMETER	SYMBOL	MIN	TYP	MAX	UNIT	TEST CONDITION
Supply Current	I _{LED}	—	100	150	mA	V=3.9V
Supply Voltage	V	—	3.9		V	—
Reverse Voltage	V _R	—	8	—	V	—
Luminous Intensity	I _V	16		—	cd/m ²	I _{LED} =100mA
Wave Length	λ _p	—	595	—	nm	I _{LED} =100mA
Life Time	—	—	100K	—	Hr.	V ≤ 3.9V

8 QUALITY ASSURANCE SPECIFICATION

8.1 CONFORMITY

The performance, function and reliability of the shipped products conform to the Product Specification.

8.2 DELIVERY ASSURANCE

8.2.1 Delivery inspection standards.

- MIL-STD-105E, general inspection level II, single sampling level;
- IPC-AA610 rev. C, class 2 electronic assemblies standard

The quality assurance levels are shown below:

Rank	Item Inspected	Defect type	AQL	Remark
Critical defect	Display	Non display	0.65%	Display malfunction
		Over current		
		Missing segment		
		Wrong viewing direction		
		Backlight OFF		
	Dimension	PCB and bezel out of specification	0.65%	Assembly failure
Major defect	Display	Incorrect operating	1.0%	
	Backlight	Flashing, dust		
		Wrong colour		
Minor defect	LCD	Black and white spot	2.5%	Appearance defect
		Black and white lines		
		Polariser scratch		
		Bubbles in polariser		
		Segment deformation, pin hole		
		Colour uniformity		
		Glass chip		
	COB	Wire bond pad exposed		
		Insufficient covering with resin (wire bond line exposed)		
		Bubble, dust on COB		
	PCB	Dust, solder ball on PCB		
Pad scratch				
Total			2.5%	

8.2.2 Zone definition

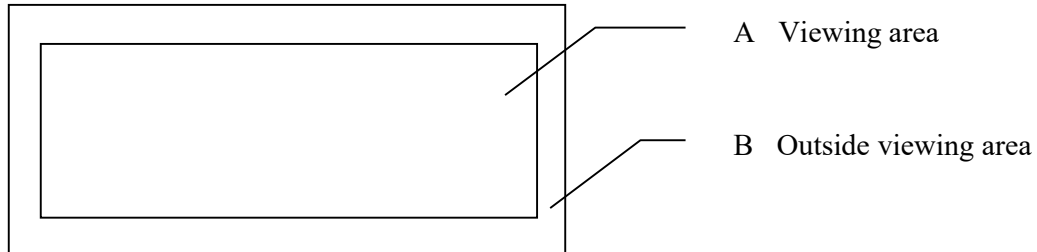

8.2.3 Visual inspection

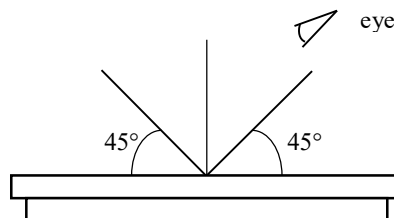

- Inspect under 2x20W or 40W fluorescent lamp (approximately 3000 lux) leaving 25 to 30 cm between the module and the lamp and 30 cm between the module and the eye (measuring position).
- Appearance is inspected at the best contrast voltage (best contrast is adjusted considering clearness and crosstalk on screen).
- Inspect the module at 45° right and left, top and bottom.
- Use the optimum viewing angle during the contrast inspection.

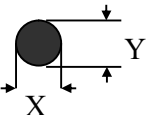
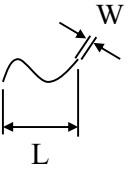
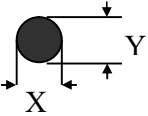
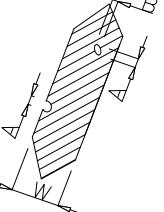

8.2.4 Standard of appearance inspection

Units: mm

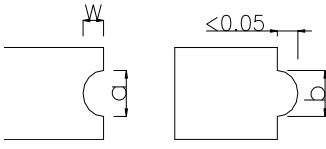
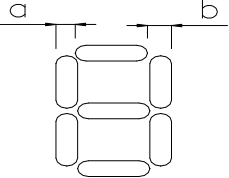
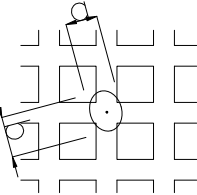
No	Item	Criteria																																			
1	Black spot, white spot, dust	<p>Round type: as per following drawing $\varnothing = (X+Y)/2$</p>  <table border="1" style="margin-left: 200px;"> <thead> <tr> <th colspan="3">Acceptable quantity</th> </tr> <tr> <th>Size</th> <th>Zone A</th> <th>Zone B</th> </tr> </thead> <tbody> <tr> <td>$\varnothing < 0.1$</td> <td>Any number</td> <td rowspan="4">Any number</td> </tr> <tr> <td>$0.1 < \varnothing < 0.2$</td> <td>6</td> </tr> <tr> <td>$0.2 < \varnothing < 0.3$</td> <td>2</td> </tr> <tr> <td>$0.3 < \varnothing$</td> <td>0</td> </tr> </tbody> </table> <p>Line type: as per following drawing</p>  <table border="1" style="margin-left: 200px;"> <thead> <tr> <th colspan="4">Acceptable quantity</th> </tr> <tr> <th>Length</th> <th>Width</th> <th>Zone A</th> <th>Zone B</th> </tr> </thead> <tbody> <tr> <td>--</td> <td>$W \leq 0.02$</td> <td>Any number</td> <td rowspan="4">Any number</td> </tr> <tr> <td>$L \leq 3.0$</td> <td>$0.02 < W \leq 0.03$</td> <td rowspan="2">2</td> </tr> <tr> <td>$L \leq 2.5$</td> <td>$0.03 < W \leq 0.05$</td> </tr> <tr> <td>--</td> <td>$0.05 < W$</td> <td>As round type</td> </tr> </tbody> </table> <p style="text-align: center;">Total acceptable quantity: 3</p>	Acceptable quantity			Size	Zone A	Zone B	$\varnothing < 0.1$	Any number	Any number	$0.1 < \varnothing < 0.2$	6	$0.2 < \varnothing < 0.3$	2	$0.3 < \varnothing$	0	Acceptable quantity				Length	Width	Zone A	Zone B	--	$W \leq 0.02$	Any number	Any number	$L \leq 3.0$	$0.02 < W \leq 0.03$	2	$L \leq 2.5$	$0.03 < W \leq 0.05$	--	$0.05 < W$	As round type
Acceptable quantity																																					
Size	Zone A	Zone B																																			
$\varnothing < 0.1$	Any number	Any number																																			
$0.1 < \varnothing < 0.2$	6																																				
$0.2 < \varnothing < 0.3$	2																																				
$0.3 < \varnothing$	0																																				
Acceptable quantity																																					
Length	Width	Zone A	Zone B																																		
--	$W \leq 0.02$	Any number	Any number																																		
$L \leq 3.0$	$0.02 < W \leq 0.03$	2																																			
$L \leq 2.5$	$0.03 < W \leq 0.05$																																				
--	$0.05 < W$	As round type																																			
2	Polariser scratch	Scratch on protective film is permitted Scratch on polariser: same as No. 1																																			
3	Polariser bubble	<p>$\varnothing = (X+Y)/2$</p>  <table border="1" style="margin-left: 200px;"> <thead> <tr> <th colspan="3">Acceptable quantity</th> </tr> <tr> <th>Size</th> <th>Zone A</th> <th>Zone B</th> </tr> </thead> <tbody> <tr> <td>$\varnothing < 0.3$</td> <td>Any number</td> <td rowspan="4">Any number</td> </tr> <tr> <td>$0.3 < \varnothing < 1.0$</td> <td>3</td> </tr> <tr> <td>$1.0 < \varnothing < 1.5$</td> <td>1</td> </tr> <tr> <td>$1.5 < \varnothing$</td> <td>0</td> </tr> </tbody> </table> <p style="text-align: center;">Total acceptable quantity: 4</p>	Acceptable quantity			Size	Zone A	Zone B	$\varnothing < 0.3$	Any number	Any number	$0.3 < \varnothing < 1.0$	3	$1.0 < \varnothing < 1.5$	1	$1.5 < \varnothing$	0																				
Acceptable quantity																																					
Size	Zone A	Zone B																																			
$\varnothing < 0.3$	Any number	Any number																																			
$0.3 < \varnothing < 1.0$	3																																				
$1.0 < \varnothing < 1.5$	1																																				
$1.5 < \varnothing$	0																																				
4	Segment deformation	<p>1.a. Pin hole on segmented display</p> <p>W: segment width $\varnothing = (A+B)/2$</p>  <table border="1" style="margin-left: 200px;"> <thead> <tr> <th colspan="3">Acceptable quantity</th> </tr> <tr> <th>Width</th> <th colspan="2">\varnothing</th> </tr> </thead> <tbody> <tr> <td>$W \leq 0.4$</td> <td>$\varnothing \leq 0.2$</td> <td>and $\varnothing \leq 1/2W$</td> </tr> <tr> <td>$W > 0.4$</td> <td>$\varnothing \leq 0.25$</td> <td>and $\varnothing \leq 1/3W$</td> </tr> </tbody> </table> <p style="text-align: center;">Total acceptable quantity: 1 defect per segment Pin holes with \varnothing under 0.10 mm are acceptable</p>	Acceptable quantity			Width	\varnothing		$W \leq 0.4$	$\varnothing \leq 0.2$	and $\varnothing \leq 1/2W$	$W > 0.4$	$\varnothing \leq 0.25$	and $\varnothing \leq 1/3W$																							
Acceptable quantity																																					
Width	\varnothing																																				
$W \leq 0.4$	$\varnothing \leq 0.2$	and $\varnothing \leq 1/2W$																																			
$W > 0.4$	$\varnothing \leq 0.25$	and $\varnothing \leq 1/3W$																																			

No	Item	Criteria																												
4	Segment deformation	<p>1b. Pin hole on dot matrix display</p>  <table border="1" data-bbox="993 323 1367 491"> <thead> <tr> <th colspan="2">Acceptable quantity</th> </tr> <tr> <th>Size</th> <th></th> </tr> </thead> <tbody> <tr> <td>$a, b < 0.1$</td> <td>Any number</td> </tr> <tr> <td>$(a+b)/2 \le 0.1$</td> <td>Any number</td> </tr> <tr> <td>$0.5 < \varnothing < 1.0$</td> <td>3</td> </tr> </tbody> </table> <p>Total acceptable quantity: 7</p> <p>2. Segments / dots with different width</p>  <table border="1" data-bbox="993 684 1367 785"> <thead> <tr> <th colspan="2">Acceptable</th> </tr> </thead> <tbody> <tr> <td>$a \geq b$</td> <td>$a/b \leq 4/3$</td> </tr> <tr> <td>$a < b$</td> <td>$a/b > 4/3$</td> </tr> </tbody> </table> <p>3. Alignment layer defect</p> <p>$\varnothing = (a+b)/2$</p>  <table border="1" data-bbox="993 882 1367 1092"> <thead> <tr> <th colspan="2">Acceptable quantity</th> </tr> <tr> <th>Size</th> <th></th> </tr> </thead> <tbody> <tr> <td>$\varnothing \leq 0.4$</td> <td>Any number</td> </tr> <tr> <td>$0.4 < \varnothing \leq 1.0$</td> <td>5</td> </tr> <tr> <td>$1.0 < \varnothing \leq 1.5$</td> <td>3</td> </tr> <tr> <td>$1.5 < \varnothing \leq 2.0$</td> <td>2</td> </tr> </tbody> </table> <p>Total acceptable quantity: 7</p>	Acceptable quantity		Size		$a, b < 0.1$	Any number	$(a+b)/2 \le 0.1$	Any number	$0.5 < \varnothing < 1.0$	3	Acceptable		$a \geq b$	$a/b \leq 4/3$	$a < b$	$a/b > 4/3$	Acceptable quantity		Size		$\varnothing \leq 0.4$	Any number	$0.4 < \varnothing \leq 1.0$	5	$1.0 < \varnothing \leq 1.5$	3	$1.5 < \varnothing \leq 2.0$	2
Acceptable quantity																														
Size																														
$a, b < 0.1$	Any number																													
$(a+b)/2 \le 0.1$	Any number																													
$0.5 < \varnothing < 1.0$	3																													
Acceptable																														
$a \geq b$	$a/b \leq 4/3$																													
$a < b$	$a/b > 4/3$																													
Acceptable quantity																														
Size																														
$\varnothing \leq 0.4$	Any number																													
$0.4 < \varnothing \leq 1.0$	5																													
$1.0 < \varnothing \leq 1.5$	3																													
$1.5 < \varnothing \leq 2.0$	2																													
5	Colour uniformity	Level of sample for approval set as limit sample																												
6	Backlight	<p>The backlight colour should correspond to the product specification</p> <p>Flashing and or unlit backlight is not allowed</p> <p>Dust larger than 0.25 mm is not allowed</p>																												
7	COB	<p>Exposed wire bond pad is not allowed</p> <p>Insufficient covering with resin is not allowed (wire bond line exposed)</p> <p>Dust or bubble on the resin are not allowed</p>																												
8	 <p>PCB</p>	<p>No unmelted solder paste should be present on PCB</p> <p>Cold solder joints, missing solder connections, or oxidation are not allowed</p> <p>No residue or solder balls on PCB are allowed</p> <p>Short circuits on components are not allowed</p>																												

9 RELIABILITY SPECIFICATION

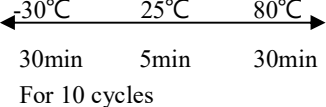
Test Item	Test Condition	Description
High Temperature Operation	50°C or 70°C 200hrs	Endurance test applying the electric stress (Voltage & Current) and the thermal stress to the element for a long time.
Low Temperature Operation	0°C or -20°C 200hrs	Endurance test applying the electric stress under low temperature for a long time.
High Temperature Storage	70°C or 80°C 200hrs	Endurance test applying the high storage temperature for a long time.
Low Temperature Storage	-20°C or -30°C 200hrs	Endurance test applying the high storage temperature for a long time.
High Temperature & High Humidity Storage	80°C,90%RH 96hrs	Endurance test applying the high temperature and high humidity storage for a long time.
Thermal Shock Test	 <p>For 10 cycles</p>	Endurance test applying the low and high temperature cycle. Burn In Test.
Vibration	10~22Hz→1.5mmp-p 22~500Hz→1.5G Total 0.5hrs	Endurance test applying the vibration during transportation and using.
ESD	VS=800V,RS=1.5kΩ CS=100pF	Endurance test applying the electric stress to the terminal.
Shock Test	50G Half sign wave 11 msdc 3 times of each direction	Constructional and mechanical endurance test applying the shock during transportation.

10 HANDLING PRECAUTIONS

Safety

If the LCD panel breaks, be careful not to get the liquid crystal fluid in your mouth or in your eyes.

If the liquid crystal touches your skin or clothes, wash it off immediately using soap and plenty of water.

Mounting and Design

Place a transparent plate (e.g. acrylic, polycarbonate or glass) on the display surface to protect the display from external pressure. Leave a small gap between the transparent plate and the display surface.

When assembling with a zebra connector, clean the surface of the pads with alcohol and keep the surrounding air very clean.

Design the system so that no input signal is given unless the power supply voltage is applied.

Caution during LCD cleaning

Lightly wipe the display surface with a soft cloth soaked with Isopropyl alcohol, Ethyl alcohol or Trichlorotrifluoroethane.

Do not wipe the display surface with dry or hard materials that will damage the polariser surface.

Do not use aromatic solvents (toluene and xylene), or ketonic solvents (ketone and acetone).

Caution against static charge

As the display uses C-MOS LSI drivers, connect any unused input terminal to VDD or VSS. Do not input any signals before power is turned on.

Also, ground your body, work/assembly table and assembly equipment to protect against static electricity.

Packaging

Displays use LCD elements, and must be treated as such. Avoid strong shock and drop from a height.

To prevent displays from degradation, do not operate or store them exposed directly to sunshine or high temperature/humidity.

Caution during operation

It is indispensable to drive the display within the specified voltage limit since excessive voltage shortens its life.

Direct current causes an electrochemical reaction with remarkable deterioration of the display quality. Give careful consideration to prevent direct current during ON/OFF timing and during operation.

Response time is extremely delayed at temperatures lower than the operating temperature range while, at high temperatures, displays become dark. However, this phenomenon is reversible and does not mean a malfunction or a display that has been permanently damaged.

If the display area is pushed on hard during operation, some graphics will be abnormally displayed but returns to a normal condition after turning off the display once.

Even a small amount of condensation on the contact pads (terminals) can cause an electro-chemical reaction which causes missing rows and columns. Give careful attention to avoid condensation.

Storage

Store the display in a dark place where the temperature is $25^{\circ}\text{C} \pm 10^{\circ}\text{C}$ and the humidity below 50%RH.

Store the display in a clean environment, free from dust, organic solvents and corrosive gases.

Do not crash, shake or jolt the display (including accessories).